



Product Summary

V _{(BR)DSS}	R _{DS(on)TYP}	I _D
-20V	2.0mΩ@-4.5V	-85A
	2.8mΩ@-2.5V	
	4.4mΩ@-1.8V	

Feature

- Trench Technology Power MOSFET
- Low R_{DS(ON)}
- Low Gate Charge
- Low Gate Resistance
- 100% UIS Tested

Application

- Power Switching Application

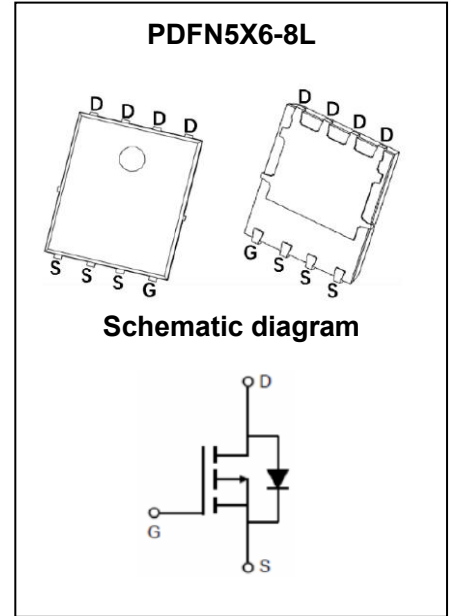

MARKING:



M023P02U = Device Code
 XX = Date Code
 Solid Dot = Green Indicator

ABSOLUTE MAXIMUM RATINGS (T_A = 25°C unless otherwise noted)

Parameter	Symbol	Value	Unit
Drain - Source Voltage	V _{DS}	-20	V
Gate - Source Voltage	V _{GS}	±12	V
Continuous Drain Current ¹	T _C = 25°C	I _D	-85 A
	T _C = 100°C	I _D	-55 A
Pulsed Drain Current ²	I _{DM}	-340	A
Single Pulsed Avalanche Current ³	I _{AS}	-43	A
Single Pulsed Avalanche Energy ³	E _{AS}	360	mJ
Power Dissipation ⁵	T _C = 25°C	P _D	125 W
Thermal Resistance from Junction to Ambient ⁶	T _A = 25°C	R _{θJA}	43 °C/W
Thermal Resistance from Junction to Case		R _{θJC}	1.0 °C/W
Junction Temperature	T _J	150	°C
Storage Temperature	T _{STG}	-55~ +150	°C

MOSFET ELECTRICAL CHARACTERISTICS ($T_A = 25^\circ\text{C}$ unless otherwise noted)

Parameter	Symbol	Test Condition	Min	Type	Max	Unit
Off Characteristics						
Drain - Source Breakdown Voltage	$V_{(BR)DSS}$	$V_{GS} = 0V, I_D = -250\mu A$	-20			V
Zero Gate Voltage Drain Current	I_{DSS}	$V_{DS} = -20V, V_{GS} = 0V$			-1	μA
Gate - Body Leakage Current	I_{GSS}	$V_{GS} = \pm 12V, V_{DS} = 0V$			± 100	nA
On Characteristics⁴						
Gate Threshold Voltage	$V_{GS(th)}$	$V_{DS} = V_{GS}, I_D = -250\mu A$	-0.4	-0.7	-1.0	V
Drain-Source On-Resistance	$R_{DS(on)}$	$V_{GS} = -4.5V, I_D = -20A$		2.0	2.8	m Ω
		$V_{GS} = -2.5V, I_D = -20A$		2.8	3.8	
		$V_{GS} = -1.8V, I_D = -20A$		4.4	5.8	
Dynamic Characteristics						
Input Capacitance	C_{iss}	$V_{DS} = -10V, V_{GS} = 0V, f = 1MHz$		8702		pF
Output Capacitance	C_{oss}			1300		
Reverse Transfer Capacitance	C_{rss}			869		
Gate Resistance	R_g	$V_{DS} = 0V, V_{GS} = 0V, f = 1MHz$		5.6		Ω
Switching Characteristics						
Total Gate Charge	Q_g	$V_{DD} = -15V, V_{GS} = -4.5V, I_D = -5A$		87.8		nC
Gate-Source Charge	Q_{gs}			10.8		
Gate-Drain Charge	Q_{gd}			21.8		
Turn-On Delay Time	$t_{d(on)}$	$V_{DD} = -10V, V_{GS} = -10V, I_D = -30A$ $R_G = 3\Omega$		15		ns
Turn-On Rise Time	t_r			50		
Turn-Off Delay Time	$t_{d(off)}$			250		
Turn-Off Fall Time	t_f			130		
Source - Drain Diode Characteristics						
Diode Forward Voltage ⁴	V_{SD}	$V_{GS} = 0V, I_S = -20A$			-1.2	V

Notes :

- 1.The maximum current rating is limited by package.And device mounted on a large heatsink
- 2.Pulse Test : Pulse Width $\leq 10\mu s$, duty cycle $\leq 1\%$.
- 3.EAS condition: $V_{DD} = -10V, V_{GS} = -4.5V, L = 0.5mH, R_G = 25\Omega$ Starting $T_J = 25^\circ\text{C}$.
- 4.Pulse Test : Pulse Width $\leq 300\mu s$, duty cycle $\leq 2\%$.
- 5.The power dissipation P_D is limited by $T_{J(MAX)} = 150^\circ\text{C}$.And device mounted on a large heatsink
- 6.Device mounted on $1in^2$ FR-4 board with 2oz. Copper, in a still air environment with $T_A = 25^\circ\text{C}$.

Typical Characteristics

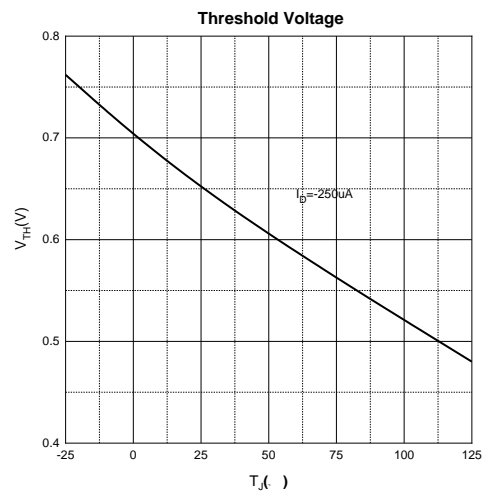
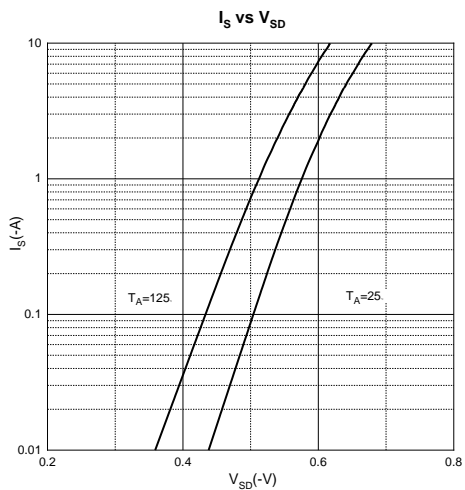
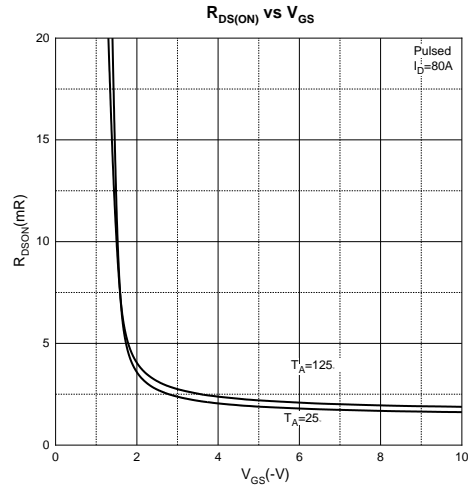
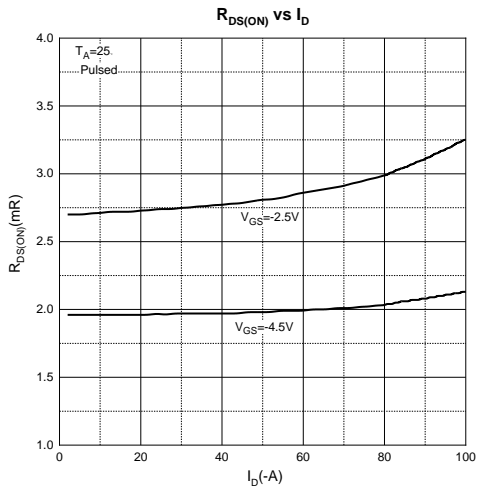
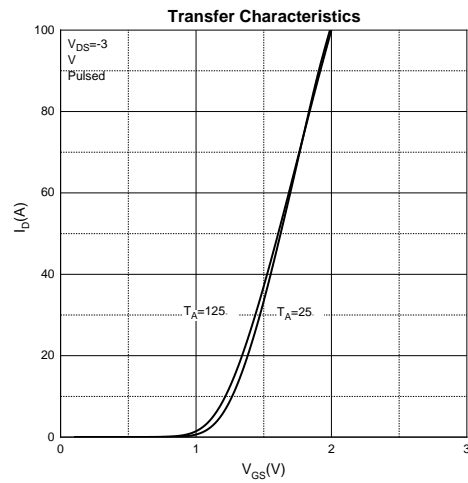
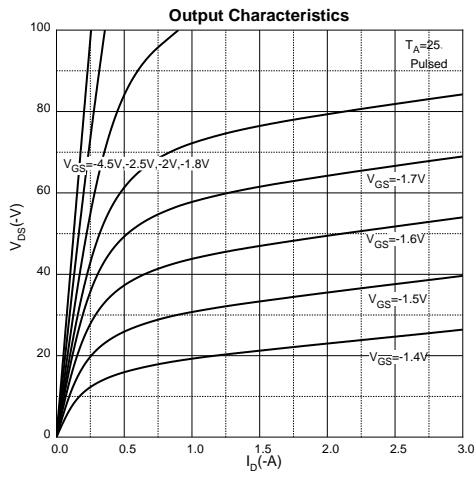

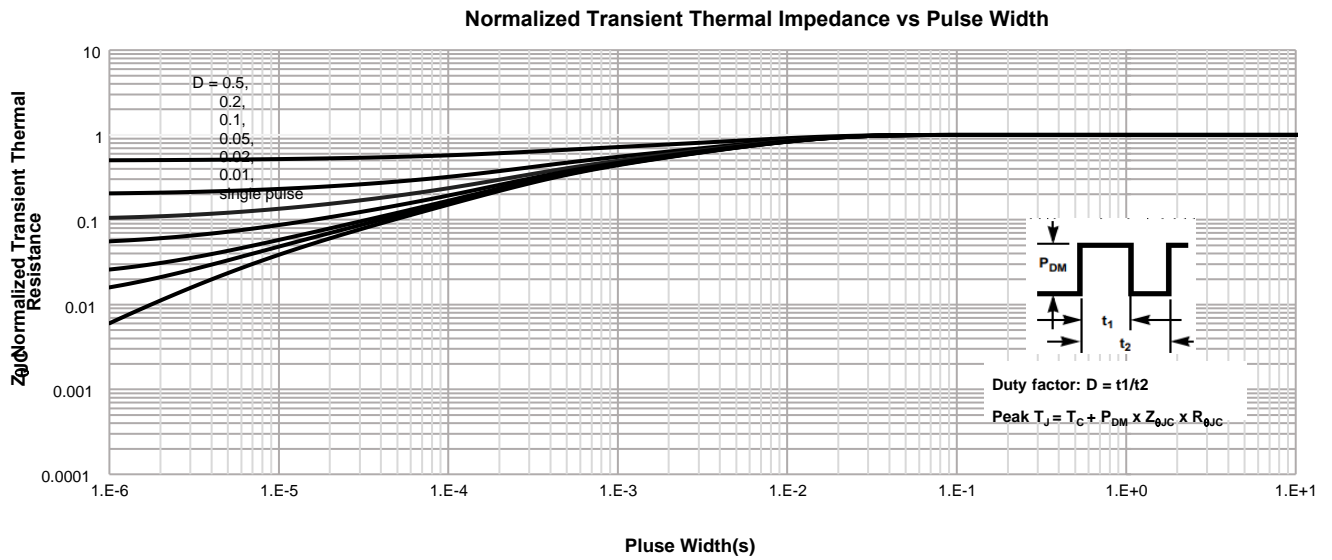
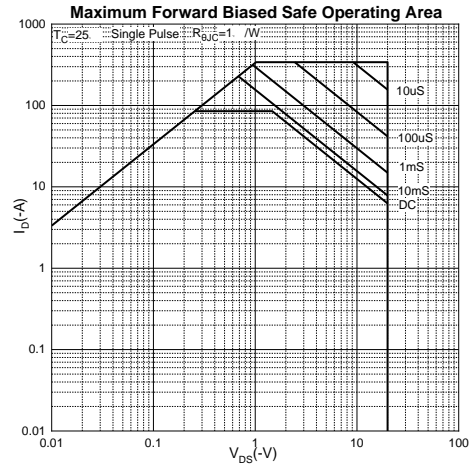
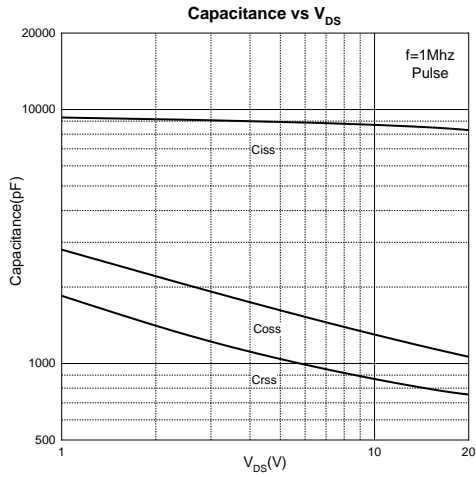

Gate Charge Test Circuit & Waveform

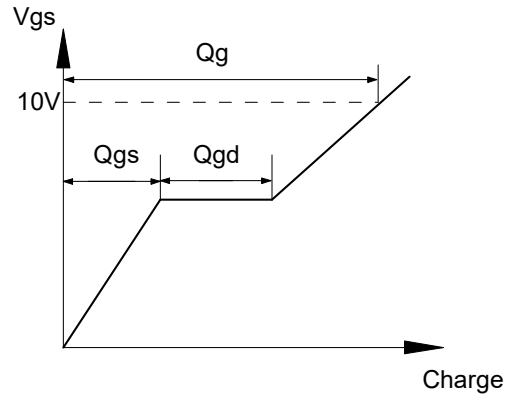
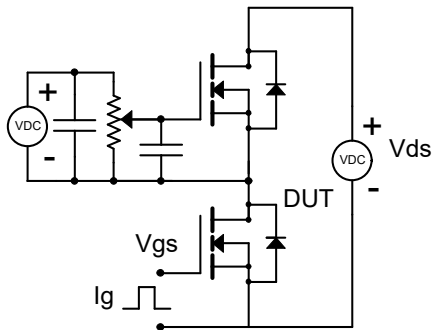

Resistive Switching Test Circuit & Waveform

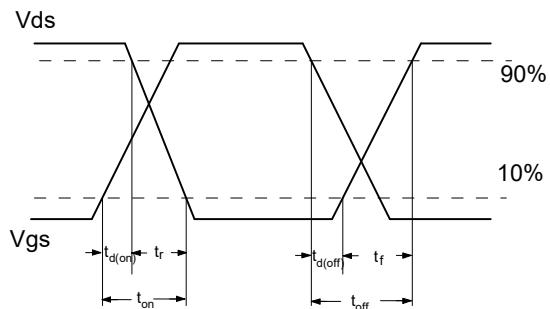
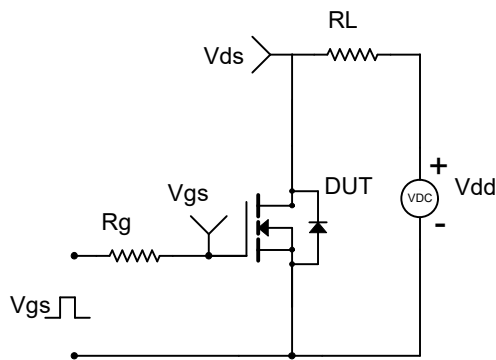

Unclamped Inductive Switching (UIS) Test Circuit & Waveforms

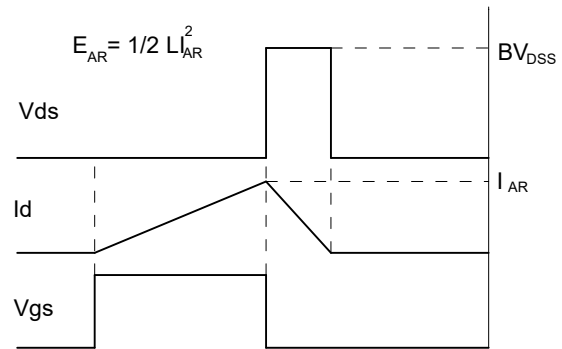
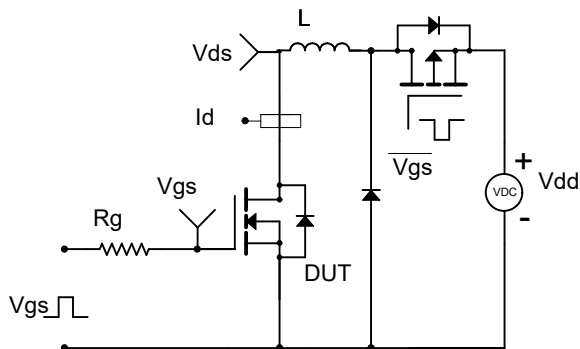

PDFN5X6-8L Package Information

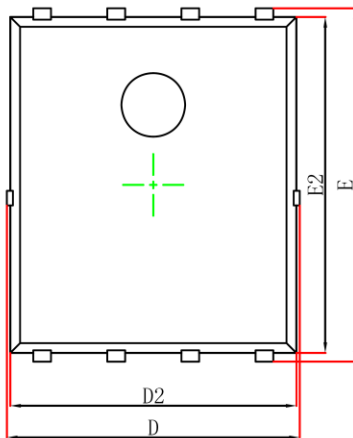

Top View
[顶视图]

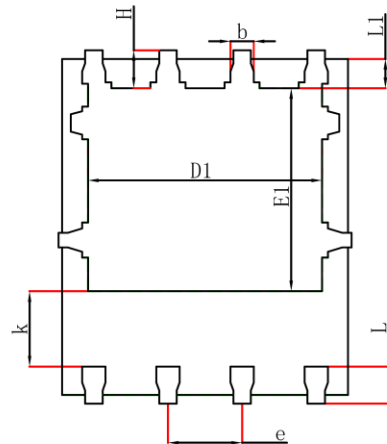

Bottom View
[背视图]

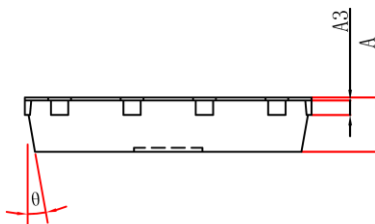

Side View
[侧视图]

Symbol	Dimensions In Millimeters		Dimensions In Inches	
	Min.	Max.	Min.	Max.
A	0.900	1.10	0.035	0.043
A3	0.254REF		0.010REF	
D	4.700	5.260	0.185	0.207
E	5.750	6.250	0.226	0.246
D1	3.560	4.500	0.140	0.177
E1	3.180	3.660	0.125	0.144
D2	4.700	5.100	0.185	0.201
E2	5.600	6.000	0.220	0.236
k	1.100	-	0.043	-
b	0.300	0.500	0.012	0.020
e	1.270TYP		0.050TYP	
L	0.510	0.710	0.020	0.028
L1	0.424	0.576	0.017	0.023
H	0.510	0.710	0.020	0.028
θ	8°	12°	8°	12°

Attention:

- GreenPower Electronics reserves the right to improve product design function and reliability without notice.
- Any and all semiconductor products have certain probability to fail or malfunction, which may result in personal injury, death or property damage. Customer are solely responsible for providing adequate safe measures when design their systems.
- GreenPower Electronics products belong to consumer electronics or other civilian electronic products.